

Set 55 TV  
Set 50 TV

Instructions for use

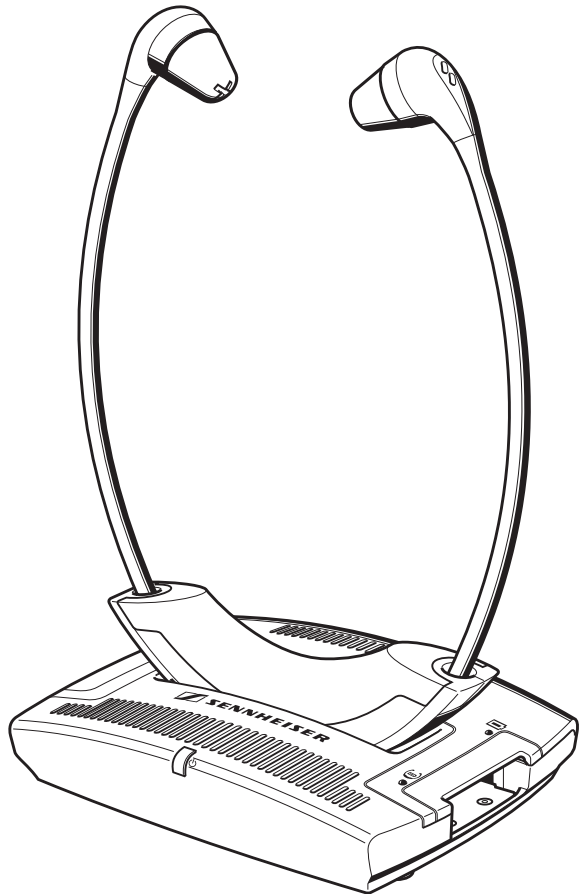



A

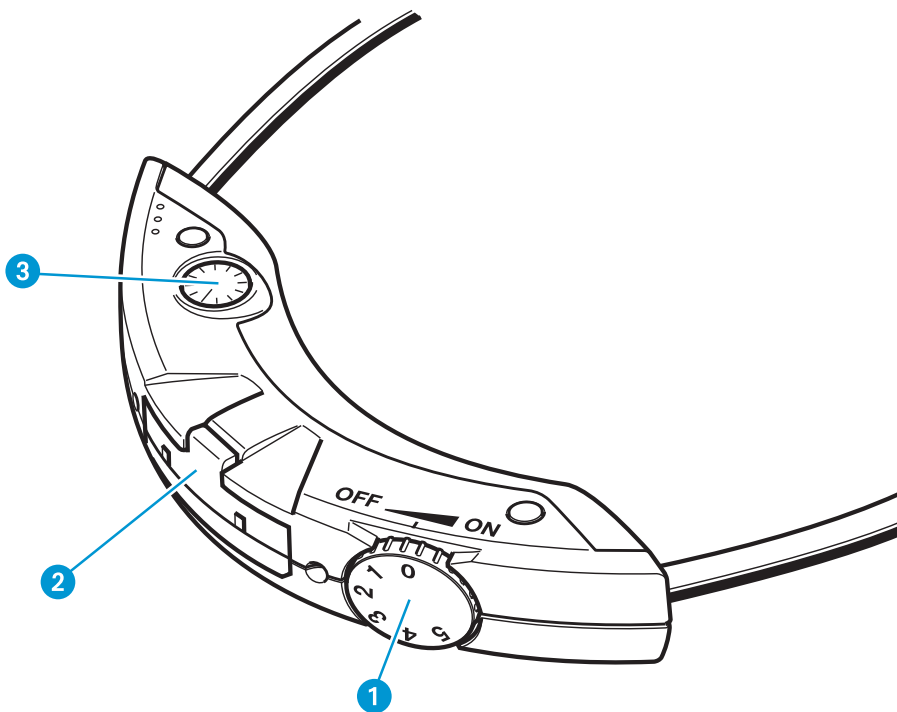

B

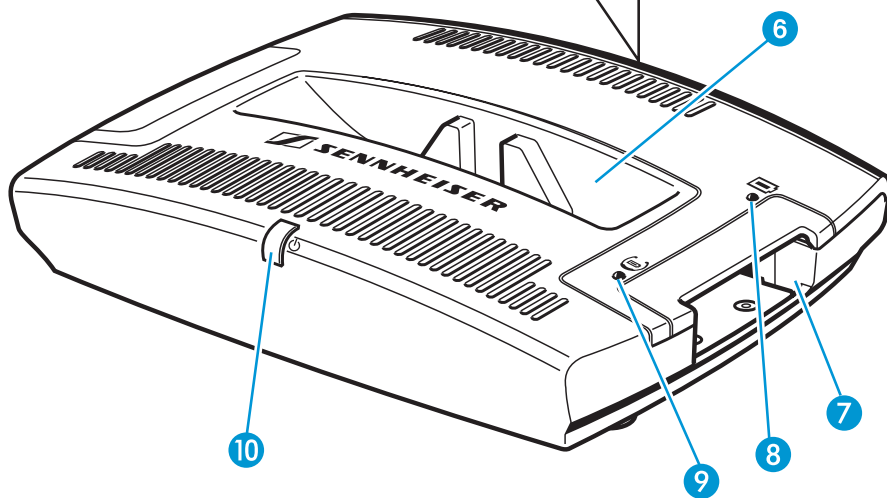
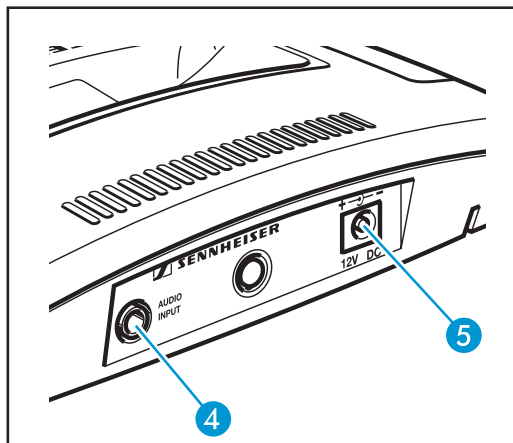

C

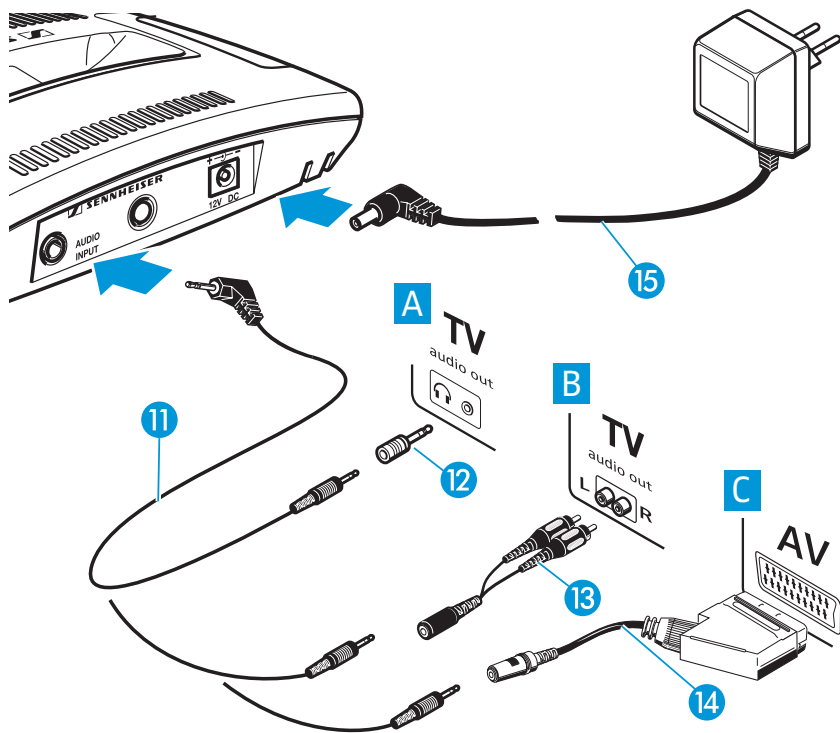

# Contents

<b>Safety instructions</b> .....	<b>2</b>
<b>The Set 50 TV/Set 55 TV stethoset receiver system</b> .....	<b>3</b>
<b>Set 50 TV: Delivery includes</b> .....	<b>3</b>
Set 55 TV product variant .....	4
<b>Operating controls</b> .....	<b>4</b>
Receiver (see inside cover) .....	4
Transmitter (see inside cover) .....	4
LED indications (see inside cover) .....	4
Connection possibilities (see inside cover) .....	4
<b>Putting the system into operation</b> .....	<b>5</b>
Setting up the transmitter .....	5
Connecting the transmitter to the sound source .....	6
Connecting the transmitter to the mains .....	8
Inserting and removing the receiver's rechargeable battery .....	8
Inserting a spare rechargeable battery into the transmitter's charging compartment .....	8
<b>Using the system components</b> .....	<b>9</b>
Switching the transmitter on .....	9
Switching the stethoset receiver on .....	9
Adjusting the volume .....	9
Adjusting the balance .....	10
Storing and charging the receiver .....	10
<b>Meaning of the LEDs</b> .....	<b>11</b>
LEDs on the transmitter .....	11
<b>Care and maintenance</b> .....	<b>12</b>
Cleaning the system .....	12
Cleaning the ear cushions .....	12
<b>If problems occur...</b> .....	<b>13</b>
<b>Accessories</b> .....	<b>14</b>
<b>Connector assignment</b> .....	<b>14</b>
<b>Specifications</b> .....	<b>15</b>
<b>Manufacturer Declarations</b> .....	<b>16</b>

Thank you for choosing Sennheiser!

We have designed this product to give you reliable operation over many years. Over 60 years of accumulated expertise in the design and manufacture of high-quality electro-acoustic equipment have made Sennheiser a world-leading company in this field.

Please take a few moments to read these instructions carefully, as we want you to enjoy your new Sennheiser products quickly and to the fullest.

## Safety instructions



- Please read these instructions carefully and completely before using the system.
- Make these instructions easily accessible to all users at all times. Always include these instructions when passing the system on to third parties.
- Do not wear the headphones in situations which require special attention (e.g. when performing skilled jobs).
- Always keep the system dry and do not expose it to extreme temperatures (ideally 10-35°C).
- Use the system with care and set it up in a clean, dust-free environment.
- Varnish or furniture polish may degrade the rubber feet of the transmitter, which could stain your furniture. You should therefore place the transmitter on a non-slip pad to avoid potential staining of furniture.
- This system allows you to set higher volumes than conventional stetho-set systems. This can cause hearing damage in persons with healthy hearing and especially in children.
- Please observe the safety instructions for NiMH rechargeable batteries on the enclosed leaflet.

### Intended use of the system

Intended use includes:

- having read these instructions, especially the chapter "Safety instructions".
- using the system within the operating conditions as described in these instructions.

### Improper use

Improper use means use of the system other than as described in these instructions or under operating conditions which differ from those described in these instructions.

# The Set 50 TV/Set 55 TV stethoset receiver system

The Set 50 TV/Set 55 TV is a cordless infra-red stethoset receiver system with which you can adjust the volume of your TV, radio, personal stereo and other hi-fi equipment to suit your individual needs. In addition, the system allows you to move around freely without the constrictions of cables within the room where the transmitter is placed..

The Set 50 TV/Set 55 TV is particularly easy and intuitive to operate. The volume can be adjusted directly on the receiver.

The transmitter has an integrated charging compartment for storing the receiver and simultaneously charging the receiver's rechargeable battery. In addition, a spare rechargeable battery can be charged in the small charging compartment at the side of the transmitter.

## Set 50 TV: Delivery includes

Delivery of the Set 50 TV stethoset receiver system includes:

- 1 RI 50 stethoset receiver
- 1 TI 50 transmitter with integrated charging compartment
- 1 BA 151 NiMH rechargeable battery
- 1 mains unit
- 1 connecting cable fitted with two 3.5 mm stereo jack plugs for connection to headphone socket (with one adapter to 1/4" (6.3 mm) jack socket)
- 1 adapter RCA socket (e.g. TB/Aux-Out)
- 2 pairs of replacement ear cushions
- Instructions for use

## Set 55 TV product variant

The scope of delivery of the Set 55 TV variant is identical to the delivery of the Set 50 TV but includes:

- 1 RI 55 stethoset receiver
- 1 TI 55 transmitter with integrated charging compartment
- 2 BA 151 NiMH rechargeable batteries

## Operating controls



### A Receiver (see inside cover)

- 1 On/Off/volume control
- 2 Compartment for BA 151 rechargeable battery
- 3 Balance control

### B Transmitter (see inside cover)

- 4 3.5 mm stereo jack socket labeled AUDIO INPUT (marked blue) for connection of sound source
- 5 DC socket labeled 12 V (marked yellow) for connection of mains unit
- 6 Charging compartment for receiver
- 7 Charging compartment for spare rechargeable battery

### B LED indications (see inside cover)

- 8 Charging control LED for spare rechargeable battery 
- 9 Charging control LED for receiver rechargeable battery 
- 10 Operation indication 

### C Connection possibilities (see inside cover)

- 11 Connecting cable for headphone socket
- 12 Adapter to 1/4" (6.3 mm) jack socket
- 13 Adapter (RCA socket)
- 14 SCART adapter (optional)
- 15 Mains connector

# Putting the system into operation

## Setting up the transmitter

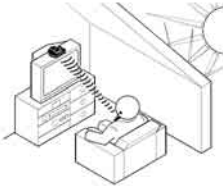

- ▶ Place the transmitter so that there are no obstacles in the light path between transmitter and receiver.

### Note:



Avoid exposure to direct sunlight. Direct sunlight may interfere with the reception and may damage the transmitter.

If you use a plasma TV screen, please observe the following to ensure interference-free reception:

- Make sure that the transmitter's infrared light beam is pointed directly at the receiver and that the light path between transmitter and receiver is not obstructed.
- If necessary, use a standard extension cable (3.5 mm stereo jack plug) to reduce the distance between transmitter and receiver. This extension cable is available from your Sennheiser dealer.

## Connecting the transmitter to the sound source

- ▶ Plug in one end of the connecting cable ⑪ to the blue AUDIO INPUT socket ④ on the transmitter.
- ▶ Check the connection possibilities of your sound source (e.g. TV).

A	B	C	D
<p>TV</p> 	<p>TV</p> <p>L  R</p>	<p>AV</p> 	No socket
Headphone socket	RCA sockets	SCART socket	External microphone

### A Connecting the transmitter via the headphone socket

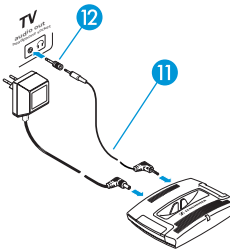

- ▶ Plug in the other end of the connecting cable ⑪ to the headphone socket on your sound source.
- ▶ Adjust the volume of the headphone socket on your sound source to a medium level. This improves the quality of cordless sound transmission. If necessary, check the menu setting of your TV.

#### Note:

With most TVs, the headphone socket is located at the front or sides. Depending on the socket, you may have to use the adapter ⑫.

In order to prevent damage to hearing, newer TVs often have a function that mutes the TV sound as soon as headphones are connected.

- ▶ If another person wants to listen to the TV sound via the loudspeaker, deactivate the muting function via the TV menu setting.

## B Connecting the transmitter via the RCA sockets

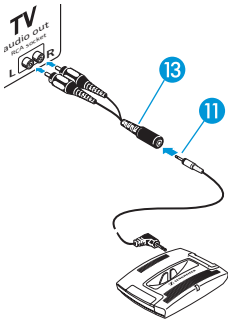

- ▶ Connect the connecting cable 11 to the adapter (RCA socket) 13.
- ▶ Connect the red and white RCA connectors of the adapter 13 to the matching red and white RCA sockets on your sound source.

### Note:

With most TVs, the RCA sockets are located at the rear.

## C Connecting the transmitter via the SCART socket

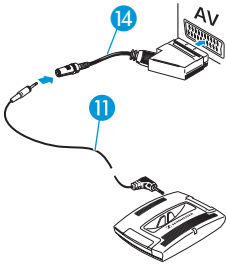

If your sound source has a SCART socket, you can order the suitable SCART adapter (see "Accessories" on page 14) from your Sennheiser dealer.

- ▶ Connect the connecting cable 11 to the SCART adapter 14.
- ▶ Plug in the SCART adapter 14 to the SCART socket on your TV. If your TV has several SCART sockets, select a SCART socket that is also an output (for details, see operating manual of your TV).

## D Using an external microphone

If your sound source doesn't have a headphone or audio output, SCART or RCA socket, you can use your system together with an external microphone (see "Accessories" on page 14).

- ▶ Connect the microphone to the blue socket AUDIO INPUT 4 on the transmitter.
- ▶ Position the microphone in front of the loudspeaker of your sound source. You can change the sound by varying the position of the microphone in front of the loudspeaker.

## Connecting the transmitter to the mains

- ▶ Connect the mains unit to the yellow socket (12 V<sub>DC</sub>) 5 on the transmitter.
- ▶ Plug the mains connector into a wall socket. The LED 10 lights up green. If the receiver is stored in the transmitter's charging compartment 6, the LED 10 goes off.

### Note:

Pull the mains connector out of the wall socket when the transmitter will not be used for extended periods of time (e.g. when you are on holiday). In this case, however, the rechargeable battery will not be recharged.

## Inserting and removing the receiver's rechargeable battery

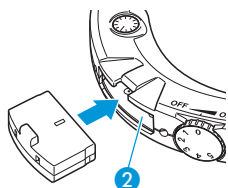

- ▶ Insert the battery into the compartment 2 as shown on the left. Make sure that the battery is inserted correctly.
- ▶ To remove the battery, use the finger catch projection to pull the battery out of the receiver.

### Note:

- The receiver is delivered with the battery inserted.
- Charge the battery for at least 3 hours before you use it for the first time (see "Storing and charging the receiver" on page 10).

## Inserting a spare rechargeable battery into the transmitter's charging compartment

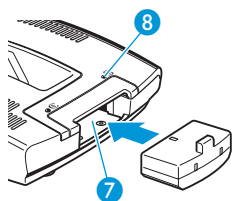

You can charge a spare battery (not included in the delivery of the Set 50 TV) in the charging compartment 7 at the side of the transmitter. This spare battery is not required for operating the Set 50 TV/Set 55 TV but offers extended listening time while the discharged first battery is being recharged.

- ▶ Insert the spare battery into the charging compartment 7 as shown on the left.
- ▶ If the rechargeable battery is inserted correctly, the LED 8 lights up red. The red LED 8 does not go off when the battery is fully charged.

# Using the system components

## Switching the transmitter on

- ▶  Take the stethoset receiver out of the transmitter's charging compartment **6**. The transmitter automatically switches on. The LED **10** lights up green.

### Note:

If the receiver is placed into the transmitter's charging compartment **6**, the transmitter automatically switches off. The LED **10** goes off.

## Switching the stethoset receiver on

### Attention! Volume up? - No!



When people use headphones, they tend to choose a higher volume than with loudspeakers. Listening at high volume levels for long periods can lead to permanent hearing defects. Please protect your hearing, Sennheiser headphones also sound exceptionally good at low volumes.

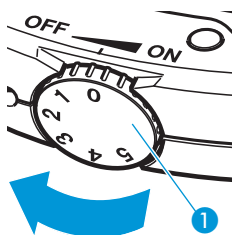

- ▶ Turn the volume control **1** in the direction of the arrow until it clicks.
- ▶ Before putting the receiver on, use the volume control **1** to adjust the volume to a low level. This protects your hearing from damage.
- ▶ Put the receiver on the correct way round, with the Sennheiser logo at the front.

## Adjusting the volume

- ▶ If the transmitter is connected to a headphones socket of your sound source:  
Adjust the volume of the sound source to a medium level. This improves the quality of cordless sound transmission.
- ▶ Use the volume control **1** to adjust the volume to a sufficient and comfortable level.

## Adjusting the balance

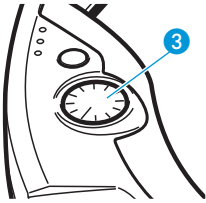

The Set 50 TV/Set 55 TV features a balance control for right/left volume adjustment.

- ▶ Use the balance control **3** to adjust the volume so that you hear equally well with both ears.

## Storing and charging the receiver

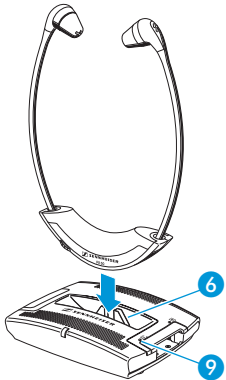

Do not store your receiver on a glass dummy head, chair armrest, or similar for long periods of time as this can reduce the contact pressure of the earbuds.



- ▶ To switch the receiver off, turn the volume control **1** backwards until it clicks.
- ▶ After use, place the receiver into the transmitter's charging compartment **6** as shown on the left, without exerting too much pressure. The transmitter automatically switches off.
- ▶  If the receiver is placed correctly into the charging compartment, the LED **9** lights up red and the battery is being charged. The red LED **9** does not go off when the battery is fully charged.
- ▶ Charge the battery for at least 14 hours before you use it for the first time. With a fully charged battery, the operating time is approx. 9 hours.

### Note:

Always store the receiver in the transmitter's charging compartment **6** to ensure that it is fully charged. The intelligent battery charging technology prevents over-charging.

# Meaning of the LEDs

## LEDs on the transmitter

LED		Status	Meaning
	Operation indication <a href="#">10</a>	lit green	The transmitter is switched on. The receiver is not stored in the transmitter's charging compartment <a href="#">6</a> .
		off	The transmitter is switched off. The receiver is stored in the transmitter's charging compartment <a href="#">6</a> .
	Charging control LED of spare rechargeable battery <a href="#">8</a>	lit red	Spare rechargeable battery or rechargeable battery is being charged
	Charging control LED of receiver rechargeable battery <a href="#">9</a>		

# Care and maintenance

## Cleaning the system

**Attention!** Liquids can damage the electronics of the units!



Liquids entering the housing of the units can cause a short-circuit and damage the electronics.

- ▶ Keep all liquids far away from the units.

- ▶ Before cleaning, disconnect the transmitter from the mains.
- ▶ Only use a slightly damp cloth to clean the units. Do not use any cleansing agents or solvents.

## Cleaning the ear cushions

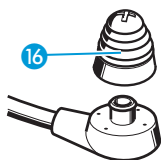

- ▶ Carefully remove the ear cushions 16 from the receiver.
- ▶ Clean the ear cushions 16 with warm soapy water and rinse thoroughly.
- ▶ Dry the ear cushions 16 before putting them back on the receiver.

### Note:

For reasons of hygiene, the ear cushions 16 should be replaced from time to time. Please order the ear cushions from your Sennheiser dealer.

## If problems occur...

► Check if the problem you face is listed in the table below:

Problem	Possible cause	Page
You cannot hear anything	• Are all jack plugs connected correctly?	6 ff
	• Is the transmitter connected to the sound source?	6 ff
	• Is the transmitter connected to the mains?	8
	• Is the volume of the sound source sufficient?	6
	• Is the green operation indication lit?	8
	• Is the volume of the receiver sufficient?	9
	• Is the rechargeable battery fully charged and inserted properly into the receiver?	8
	• Do you wear the receiver the right way round, with the Sennheiser logo at the front?	9
	• Is there a free line of sight between transmitter and receiver?	5
You hear the sound only with one ear	• Is the balance adjusted correctly?	10
The rechargeable battery is not being charged	• Is the receiver switched off during charging?	10

If problems occur that are not listed in the above table or if the problems cannot be resolved with the proposed solutions, please contact your local Sennheiser agent for assistance.

## Accessories

**Attention!** Components from other manufacturers (e.g. for power supply or rechargeable battery) may cause damage to the unit and will invalidate the warranty.



► Only use original Sennheiser accessories and spare parts.

The following accessories are available from your authorized Sennheiser dealer:

BA 151 spare rechargeable battery Cat. No. 004146

Ear cushions (normal), 5 pairs Cat. No. 517625

Ear cushions (lamellar form), 5 pairs Cat. No. 517626

SCART adapter Cat. No. 077798

3 m extension cable  
(3.5 mm stereo jack plug) Cat. No. 517627

MKE 800 TV-N Cat. No. 500974  
external microphone (mono)

## Connector assignment

The blue socket AUDIO INPUT ④ is designed for use with two different connector types (Line/Mic). The connector type used is identified automatically.

### 3.5 mm 3-pole jack/standard stereo

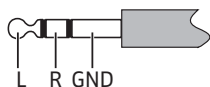

### 3.5 mm 4-pole jack/microphone with additional power supply

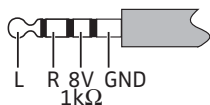

# Specifications

## System

Modulation	FM mono
Carrier frequencies	2.3 MHz
Range	approx 12 m within a room
AF frequency response	50 Hz–12 kHz
THD	< 1 %

## Transmitter

Audio /microphone connection	3.5 mm stereo jack socket
Charging time of rechargeable battery	approx. 14 hours
Power supply	12 V <sub>DC</sub> /200 mA via NT 5 mains unit
Weight	approx. 90 g
Dimensions	approx. 95 x 130 x 30 mm

## Receiver

Max. SPL	120 dB (SPL)
Power supply	via BA 151 NiMH rechargeable battery (2.4 V / 80 mAh)
Operating time	approx. 9 hours
Weight	approx. 55 g
Dimensions	approx. 200 x 150 x 20 mm

# Manufacturer Declarations

## Warranty regulations

The guarantee period for this Sennheiser product is 24 months from the date of purchase. Excluded are accessory items, rechargeable batteries that are delivered with the product; due to their characteristics these products have a shorter service life that is principally dependent on the individual frequency of use.

The guarantee period starts from the date of original purchase. For this reason, we recommend that the sales receipt be retained as proof of purchase. Without this proof (which is checked by the responsible Sennheiser service partner) you will not be reimbursed for any repairs that are carried out.

Depending on our choice, guarantee service comprises, free of charge, the removal of material and manufacturing defects through repair or replacement of either individual parts or the entire device. Inappropriate usage (e.g. operating faults, mechanical damages, incorrect operating voltage), wear and tear, force majeure and defects which were known at the time of purchase are excluded from guarantee claims. The guarantee is void if the product is manipulated by non-authorized persons or repair stations.

In the case of a claim under the terms of this guarantee, send the device, including accessories and sales receipt, to the responsible service partner. To minimise the risk of transport damage, we recommend that the original packaging is used.

Your legal rights against the seller, resulting from the contract of sale, are not affected by this guarantee. The guarantee can be claimed in all countries outside the U.S. provided that no national law limits our terms of guarantee.

## CE Declaration of Conformity

This equipment is in compliance with the essential requirements and other relevant provisions of Directive 89/336/EC. The declaration is available on the internet site at [www.sennheiser.com](http://www.sennheiser.com).

Before putting the device into operation, please observe the respective country-specific regulations!

## Rechargeable batteries



The supplied rechargeable batteries can be recycled. Please dispose of them as special waste or return them to your specialist dealer. In order to protect the environment, only dispose of exhausted rechargeable batteries.

## WEEE Declaration



Your Sennheiser product was developed and manufactured with high-quality materials and components which can be recycled and/or reused. This symbol indicates that electrical and electronic equipment must be disposed of separately from normal waste at the end of its operational lifetime.

Please dispose of this product by bringing it to your local collection point or recycling centre for such equipment. This will help to protect the environment in which we all live.



Sennheiser electronic GmbH & Co. KG  
30900 Wedemark, Germany  
Phone +49 (5130) 600 0  
Fax +49 (5130) 600 300  
[www.sennheiser.com](http://www.sennheiser.com)

Printed in China

Publ. 10/06

517640 / A02